



AEM 450 (Version: AMOSAEM450OP20180306)

Semi-automatic Microtome

Operation Manual

AMOS SCIENTIFIC PTY.LTD. ABN:37 159 778 140

www.amos-scientific.com

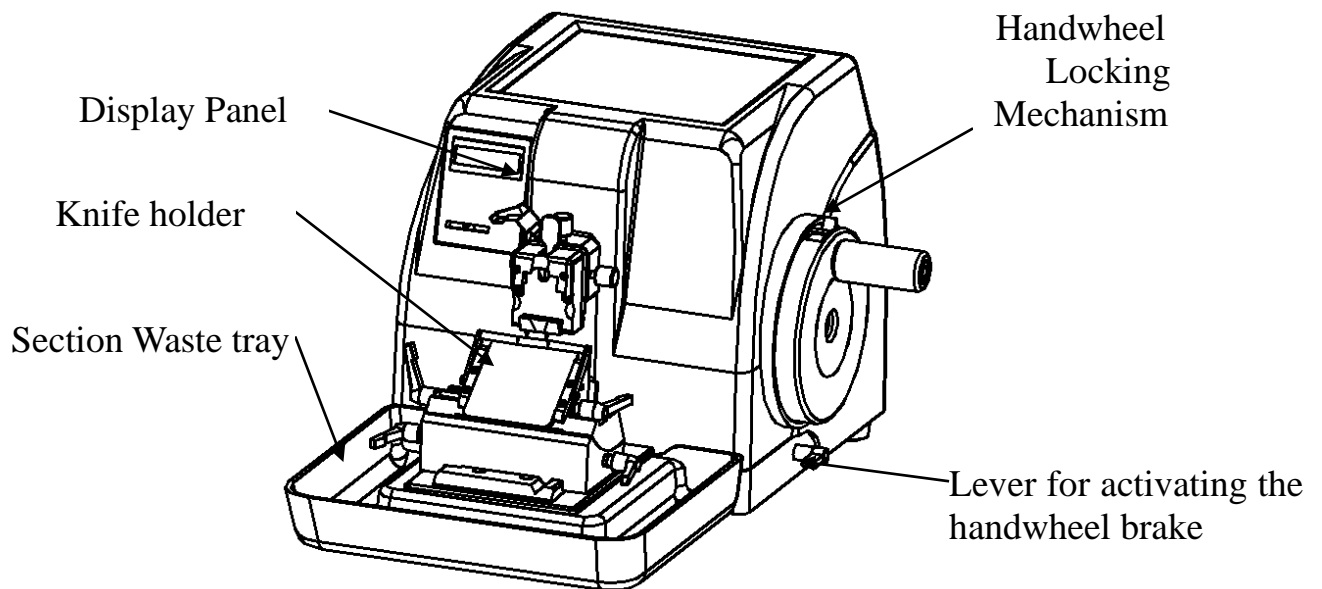

This Operation manual introduces the instruments component, key features and using notes. Be sure to read these instructions before using the instrument.

Foreward

AEM450 Semi-automatic Microtome is designed for the worldwide user. It can meet the different requirement in the fields of biology, medicine and industry.

It is necessary to read this technical manual to ensure that the instrument is snuff, long haul and safely used.

Our company is responsible for service after the microtome have been used, our agents have ability to service, the client all of world can connect with our agent in order to get timely service.

Attention: our company products will be mended and updated continually along with developing of the technology. Regarding of being updated of the technical data and instruments component, we will not inform.

Contents

1、 Safety Notes.....	1
1.1 Overview.....	1
1.2 Safety Warning.....	1
1.3 Safety Devices.....	3
2、 Performance & Parameters.....	4
2.1 Overview-Instrument Components.....	4
2.2 Performance Index.....	5
2.3 Technical Data.....	5
3、 Preparing before using.....	6
3.1 Installation Site Requirement.....	6
3.2 Standard Delivery.....	6
3.3 Installation.....	7
3.4 Electrical Connection.....	8
4、 Operation.....	9
4.1 Control Panel Function &Control.....	9
4.2 Knife Holder inserting.....	11
4.3 Clamping The Specimen.....	12
4.4 Specimen Clamps/Knife Inserting.....	13
4.5 Trimming.....	15
4.6 Sectioning.....	15
5、 Clearance & Maintenance.....	16
5.1 Cleaning The Instrument.....	16
5.2 Maintenance.....	17
6、 Trouble Shooting.....	18
7、 Instrument Diagram.....	21

1、 Safety Notes

1.1 Overview

The Instruction Manual contains important safety instructions and information. The operation manual is an important part of the instrument, which the operator must be read carefully prior to startup and use in order to running safely. It will at a critical moment to ensure personal safety and avoid instrument damage. Please keep the Manual near the instrument to easy read.

This instrument was built and test in accordance with the safety regulations as specified below:

GB4793.1-2007 Medical Electrical Equipment First Part: Current Requirements for safety.

▲ **Notes:** The safety marks and protective device on both instrument and accessories may neither be removed nor modified, so as to not injury body or instrument.

1.2 Safety Warning

The following safety notes relating to transport, installation, calibration, operation, maintenance, cleaning and all aspects of the instrument. Every principal person must be read carefully and carry out this mentioned strictly.

1.2.1 Warnings-Transport and Installation

- The instrument may only be transported or moved in an upright position always, the tilt angle should not exceed 45°C!
- After installation, please remove the section waste tray and knife holder before transporting or movement!
- The input voltage has been preset at the factory, please check this setting complies with your local power requirement before connecting the instrument to the mains power!
- Please using the power cord provided. If changing the power cord, must ensure the power cord with earth wire!
- Don't operate in rooms with explosion hazard !
- The protective devices on both instrument and accessories must neither be removed nor modified, in order to avoid injury to instrument or person body !

1.2.2 Warnings-Operation

- Take care when handling microtome knives and disposable blades. The cutting edge is extremely sharp and can cause serious injury!
- Always remove the knife/blade before detaching the knife holder from the instrument, and put the knives back into the knife box when not in use!
- Never place knife anywhere with the cutting edge facing upwards and never try to catch knife when you take out the knife!
- Always clamp the specimen block before clamping the knife!
- Prior to changing the specimen and knife, always lock the handwheel firstly. If changing the specimen only, always must cover the cutting edge with the knife guard !
- Always turn the handwheel clockwise, otherwise , the effect may affect the slice!
- Always cover the knife guard when slicing!
- Don't Clockwise and Counterclockwise rotate the handwheel frequently at top and bottom! Slice thickness many deviations!
- Ensure that liquids don't enter the interior of the instrument during working!
- Don't touch the handwheel while it is running, otherwise injury the operator!

1.2.3 Warning- Maintenance and Cleaning

- Only authorized person may do the service and repair!
- Before cleaning, always switch off the instrument, disconnect the power plug, remove the knife holder completely and clean it separately. Must remove the blade before cleaning the knife holder!
- Lock the handwheel before each cleaning!
- Don't use any solvents containing acetone or xylene for cleaning!
- Ensure that no liquids enter the interior of the instrument when cleaning!
- Don't turn on the instrument before it is completely dry!
- Turn the instrument off with the mains switch and pull the mains plug before replacing the fuses! Only use fuses of the same specification and operation in this manual.

1.3 Safety Devices

Handwheel locking mechanism

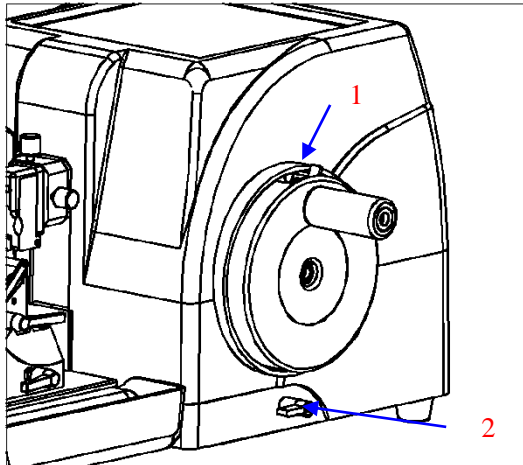

As showed in the Fig, lever(1) and(2) can be to lock the handwheel.

To clockwise push lever (1) until it lock the handwheel while specimen place at the top position.

And also can clockwise rotate lever(2) about 180° which it may lock handwheel in any position.

Rotate the lever counterclockwise to unlock the handwheel.

The Left drawing shows the status at :
Lever (1) is activated to lock and lever (2) is not activated.

● DON'T lock the handwheel when the handwheel is rotating, otherwise it will damage the instrument.

▲ **Attention:** Before remove the instrument, change specimen and blade or cleaning and maintenance the instrument, the handwheel must be locked.

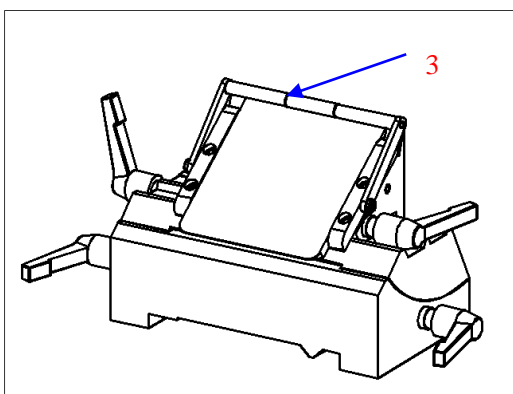

Knife Guard on the knife holder

Turn the knife guard(3) upward to cover the knife to avoid personal injury and damage the knife edge.

The knife guard (3) in the drawing is stay in protection.

● Note: Only authorized and qualified service personnel may access the internal components of the instrument.

2、 Performance & Parameters

2.1 Overview- Instrument Components

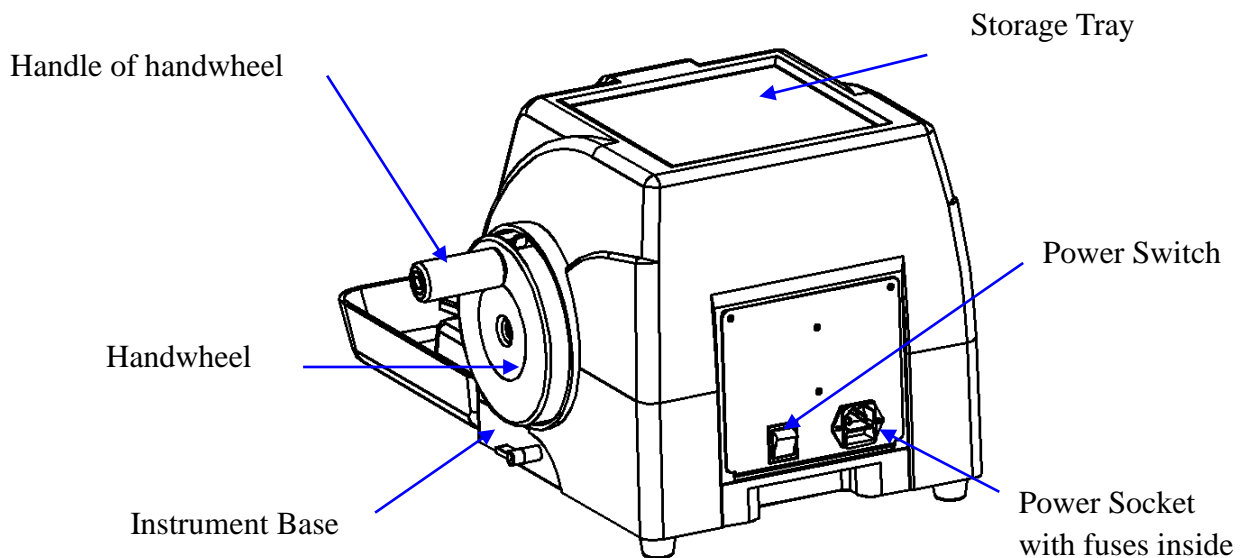
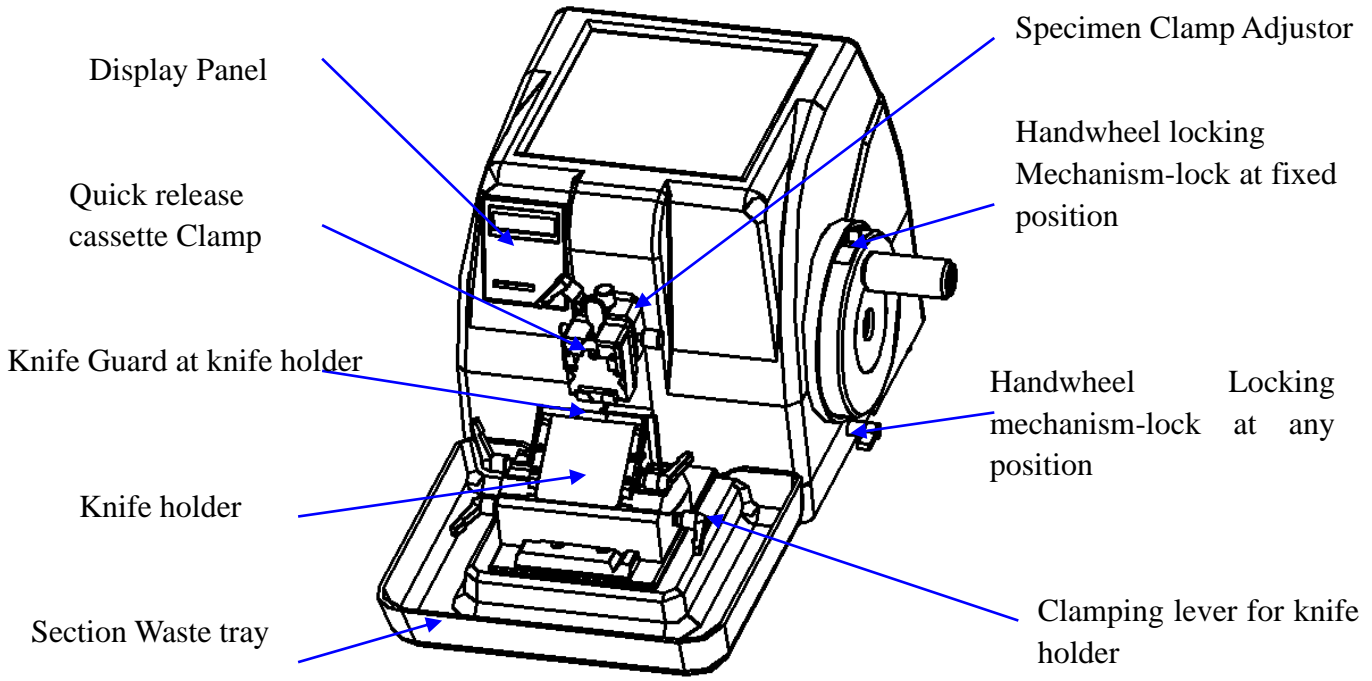

2.2 Performance Index

AEM450 semiautomatic microtome is an apparatus used for routine histological sectioning, the specimen moved in horizontally and step automatically is controlled by stepper motor. It can slice up precisely, and is easy to operate. The following is the main characteristic of this microtome:

- ⊙ the crust is made in abs project plastic with fire prevention function, and designed in linear with artistic appearance.
- ⊙ spacious ingenious assembly section waste tray.
- ⊙ retraction function make it is easier to slice up.
- ⊙ Quick release cassette clamp and specimen clamp fit to internal embedding cassette.
- ⊙ locking may be activated at any position by handwheel to ensure cassette changing safety.

2.3 Technical Data

- ⊙ Surroundings requirements:
 - Working temperature: +10℃—40℃
 - Working humidity: <80%, defrosting
 - Working pressure: (86~106) KPa;
- ⊙ Power supply: 100-240 V AC±10 %
- ⊙ Frequency: 50/60 Hz
- ⊙ Power: <60 VA
- ⊙ Fuse: 2A
- ⊙ Safe classify: Classify I - type B
- ⊙ Section thickness: 0 to 600μm
 - 0 to 2μm, 0.5μm increments
 - 2 to 10μm, 1μm increment
 - 10 to 20μm, 2μm increments
 - 20 to 100μm, 5μm increments
 - 100 to 600μm, 50μm increments
- ⊙ Trimming thickness: 0 to 600μm
 - 0 to 2μm, 0.5μm increments
 - 2 to 10μm, 1μm increment
 - 10 to 20μm, 2μm increments
 - 20 to 100μm, 5μm increments
 - 100 to 600μm, 50μm increments
- ⊙Retraction thickness: 20μm
- ⊙Specimen horizontal feed: 28mm
- ⊙Specimen vertical feed: 70mm
- ⊙Maximum specimen : 40x50x30mm, or standard cassette
- ⊙Specimen holder adjusted system: Horizontal orientation: ±8°
Vertical orientation: ±8°

- ⊙ Repositioning of knife holder base(left-right):50mm
- ⊙ Electric Coarse Feed Speed: 750μm/s
- ⊙ Dimension: Length: 550mm,
Width: 405mm , (without handwheel, 310mm),
Height: 325mm ,
- ⊙ Net Weight: about 34kgs

3、Preparing before using

3.1 Installation Site Requirement

- ⊙ Put the instrument on a steady table to ensure the instrument base is in horizon when the instrument is running.
 - ⊙ Ensure that no other goods around the instrument to avoid the shelter affecting the operator operate the instrument.
 - ⊙ The working temperature and humidity must be accord with the data in the manual.
 - ⊙ Ensure there is enough space for the handwheel running.
- ▲ **Attention:** Do not operate in rooms with explosion hazard.

3.2 Standard Delivery

⊙ Microtome(with quick release cassette clamp)	1 unit
⊙ Knife holder	1 set
⊙ Specimen clamp	1 pc
⊙ Waste tray	1 pc
⊙ 2.5 Allen wrench(M3)	1 pc
⊙ 3 Allen wrench(M4)	1 pc
⊙ Dust Cover	1 pc
⊙ Disposable blade	1 box
⊙ Power Cord	1 pc
⊙ Fuse	2 pcs
⊙ Operation Manual	1 pc

● Please carefully check out the supply with the packing list after open the carton. If you have any doubt, immediately contact the seller. If the client has any special requirement, please illuminate it before order.

3.3 Installation

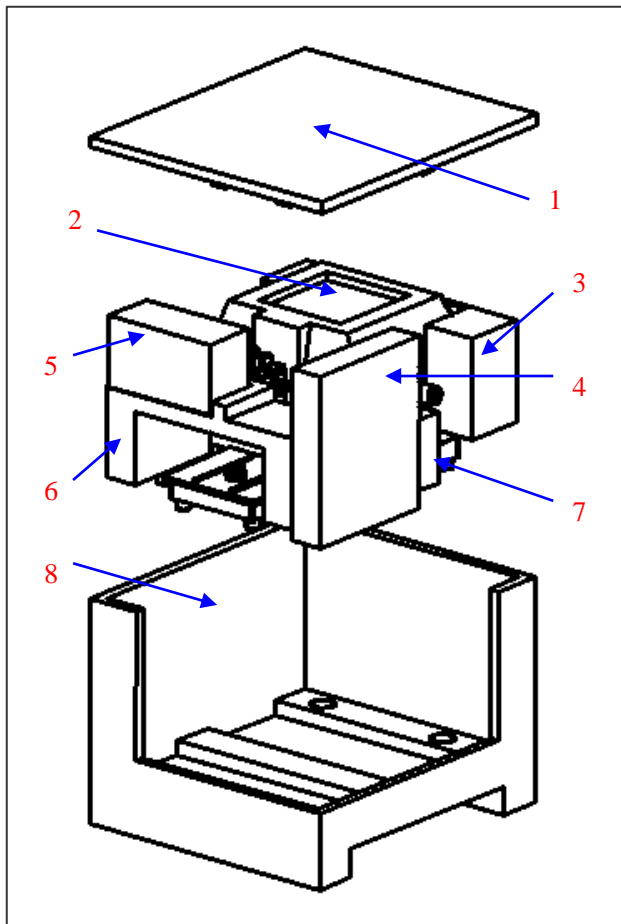

3.3.1 Unpacking

As Fig shows:

- ⊙ Box Cover (1)
- ⊙ Microtome (2)
- ⊙ Back protect board (3)
- ⊙ Waste Tray (4)
- ⊙ Knife holder (5)
- ⊙ Front protect board (6)
- ⊙ Specimen Clamp (7)
- ⊙ Box Base (8)

Cut off the tie and then remove the cover (1), and then take knife holder (5), waste tray (4), standard cassette clamp (7), front protect board (6), back protect board (3) and then the instrument(2) in turn. Final to take out other accessories in the inner package to install the instrument.

3.3.2 Knife holder

Take the knife holder (9) out from the box, push it along the track as it is showed in the Fig, and then rotate the knife holder locking lever (10) to lock the knife holder.

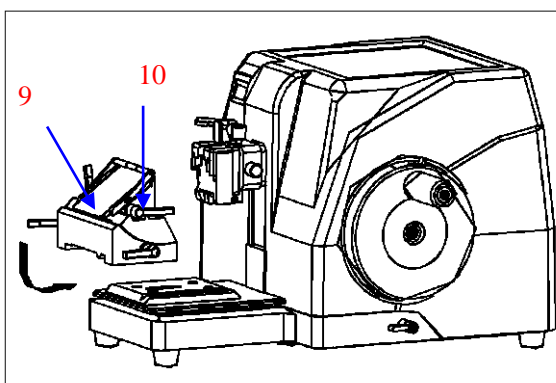

3.3.3 Section Waste Tray

Take the waste tray(11) out from the box and push it along the track as it is showed in the Fig

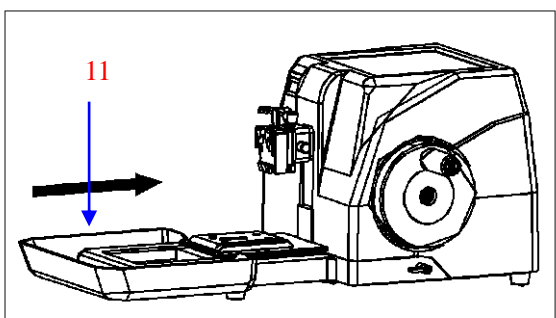

3.4 Electrical Connection

- The voltage has been preset at the factory. Before connecting the instrument to the power, please check that this setting complies with the local power requirements of your laboratory.
- Connect the instrument to a grounded power socket, to avoid accident.
- It is better to use the power cable provided or use an extension cord with a ground wire.

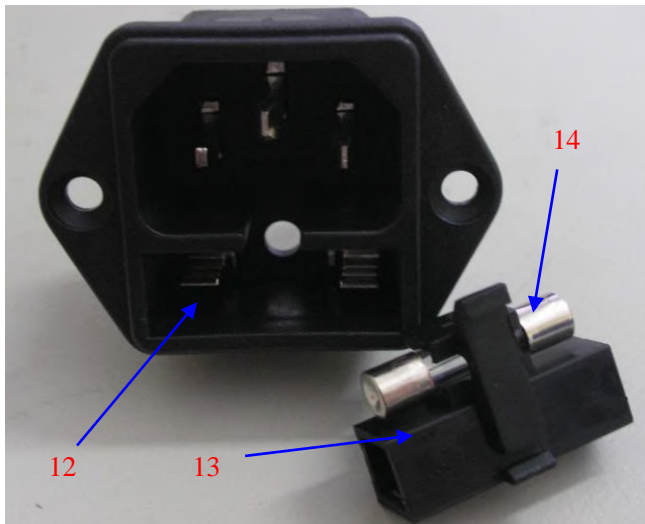

- Insert the fuse(14) into the fuse socket (13) as it is showed in the Fig and insert the whole fuse socket into the socket (12).

● **Attention:** Cut off the power supply and then pull the plug before change the fuse. To ensure trouble-free operation of the instrument, make sure to comply with the explanation in the operation manual.

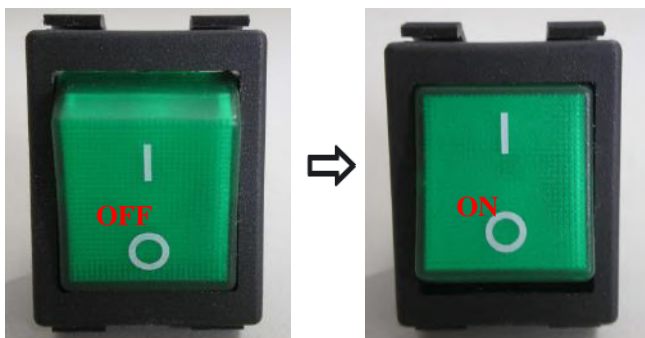

- Power off as the left fig show and Power on as right fig show.

● After the microtome is switched on, the display field in the control panel is lit up. And the specimen holder will back to zero automatically. A beep sound will follow.

4、 Operation

4.1 Control Panel Function &Control

All the parameters are set and displayed via control panel. After power on, use the control panel to operate the instrument, the following is the distribution and explanation of control panel.

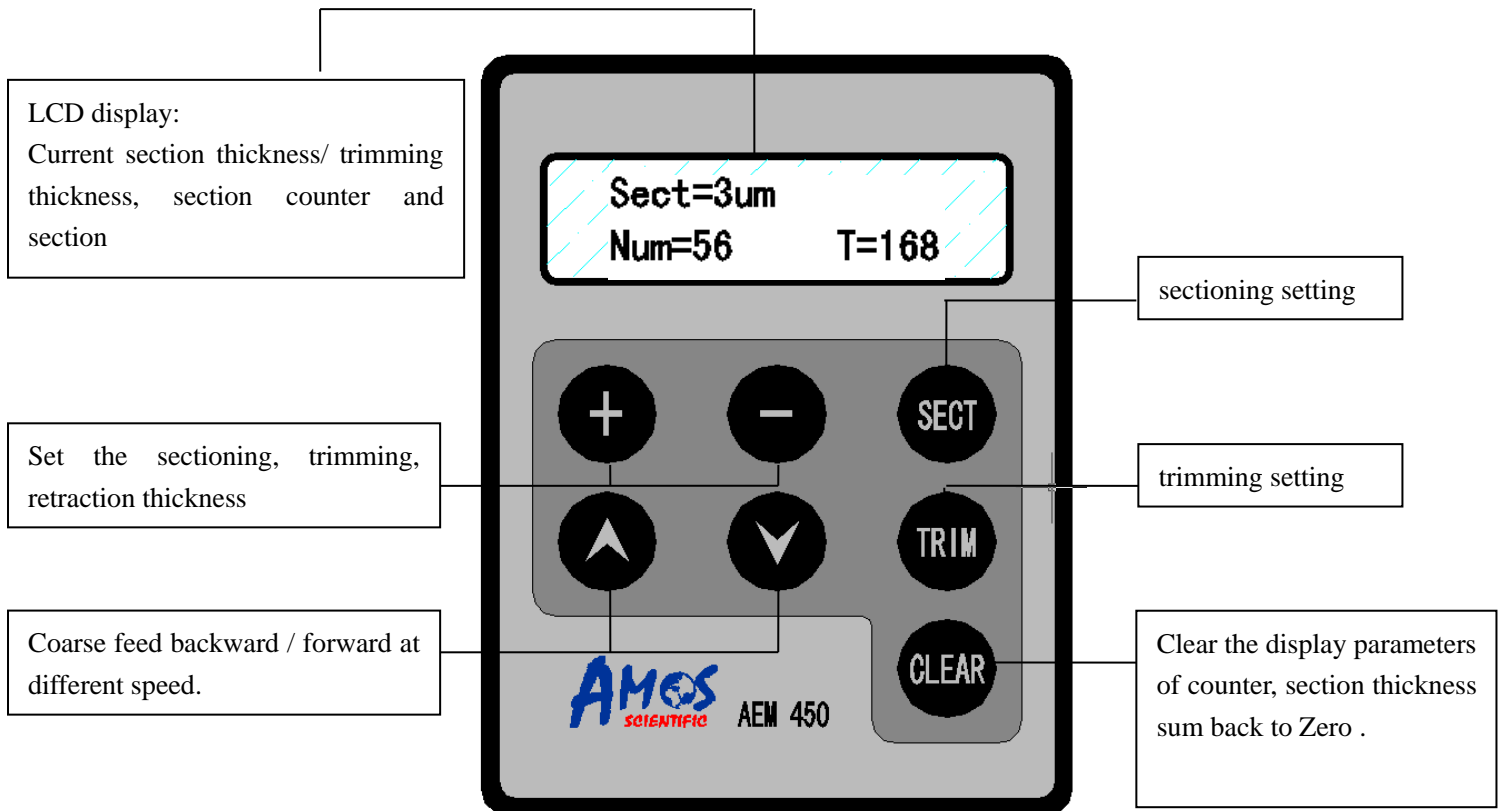

Sect=3um
Num=56 **T=168**



The LCD display area for two lines with blue screen and white words.

The first line displays: Current set value of section Thickness/trimming section thickness setting

The second line displays: section/trimming counter and section thickness sum.

- The trimming status be stand by when instrument switch on.

SECT: Active the sectioning mode to set the sectioning value.

TRIM: Active the trimming mode to set the trimming value.

- The displayed value is the set before the last power off when the machine is power on.



CLEAR button

Clear the display (section counter or section thickness sum) to 0.

● The system will automatic clear the section and thickness number when the machine switch on.



Buttons for setting the section thickness / trimming section thickness/ retraction value

Section thickness setting range: 0 μ m to 600 μ m

Setting values: From 0 μ m to 2 μ m, in 0.5 μ m increments

From 2 μ m to 10 μ m, in 1 μ m increments

From 10 μ m to 20 μ m, in 2 μ m increments

From 20 μ m to 100 μ m, in 5 μ m increments

From 100 μ m to 600 μ m, in 50 μ m increments



Buttons for coarse feed backward/forward

Quickly to adjust the movement of coarse feed, the speed is 750 μ m/s

● Specimen feed is 20mm. If exceed the value, the buzzer will alarm with voice and the specimen movement stopped.

4.2 Knife Holder inserting

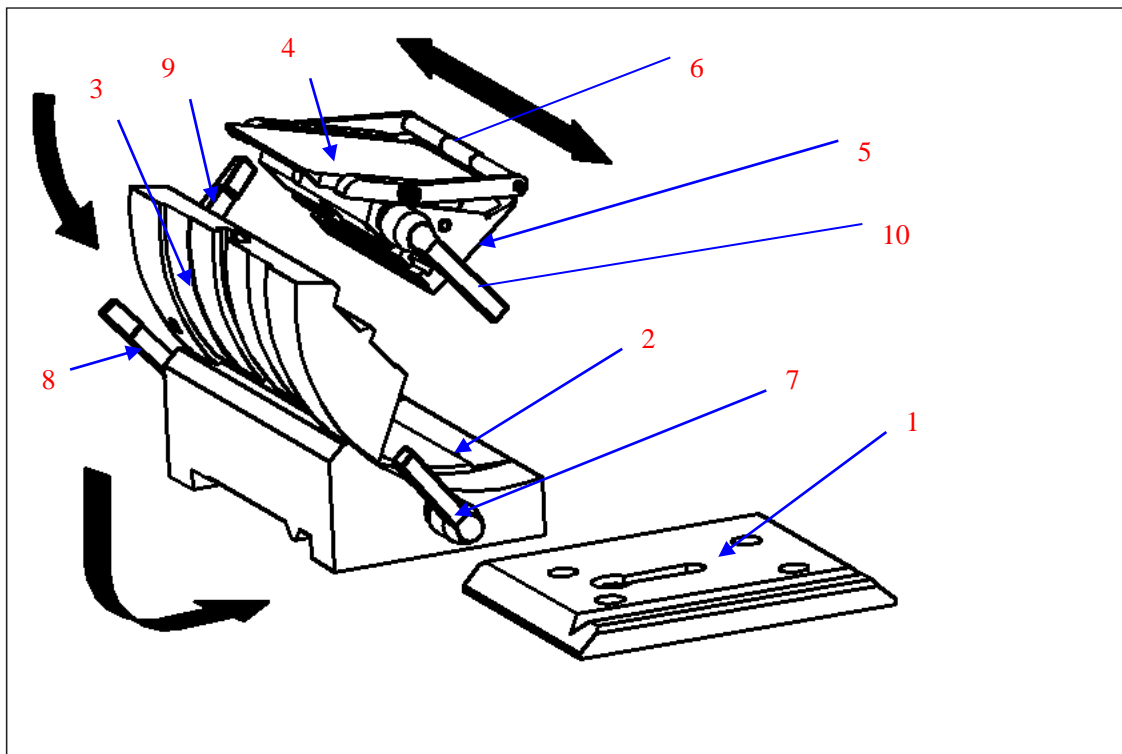

As the drawing shows, the knife holder be composed of the following parts: Z axis slider (1) , Y axis slider (2) , X axis slider (3) , clamp2 (4) , clamp1 (5) , knife guard (6) , lever 2 (7) , lever 2 (8) , lever 2 (9) ,lever 1 (10) .

- ⊙ Insert the Y axis slider(2) into the track of Z axis slider(1) , and then insert the lever 2 (7) and rotate it until the slider securely clamped and then adjust the adjustable handle of the lever 2 (7) to horizontal position.
- ⊙ Rotate the rotating X axis slider (3) to slide it into the Y axis slider (2), and then insert the lever 2 (8), and rotate it until the slider securely clamped, and then adjust the adjustable handle of the lever 2 (8) to horizontal position.
- ⊙ Place the clamp(4) and clamp(5)on the X axis slider (3), and then rotate lever 2 (9) to lock , adjust the adjustable handle of the lever 2(9) to the vertical position.
- ⊙ Rotate the Lever 1(10) to lock the clamp2 (4) and clamp1 (5) .
- ⊙ Turn the knife guard(6) over the knife edge to avoid the accidental injury.

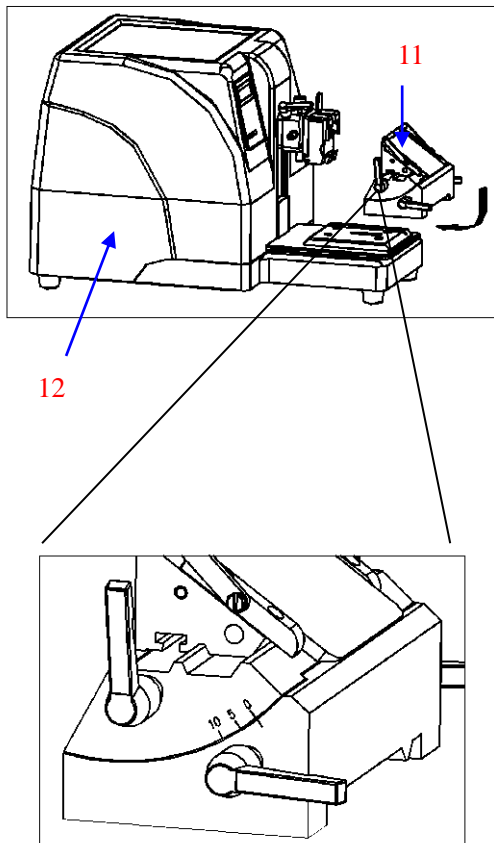

Knife holder and the instrument base holder

Insert the knife holder(11) along the track of the base holder(12), and then rotate lever 2 (7) to lock and adjust the adjustable handle of the lever 2(7) to horizontal position.

▲ Attention: Always remove the knife before detaching the knife holder from the instrument. Always put the knives back into the knife case when not in use.

Tighten the knife holder and the base holder by the four levers and adjust the rotating angle as requirement before tighten it.

The rotating angle is from 0 to 10 degree (see the picture), the user can adjust the angle in this range according to the requirement.

▲ Caution: Take care to operate the knife holder and the knife, it is very sharp and easy to cause serious injury.

4.3 Clamping the Specimen

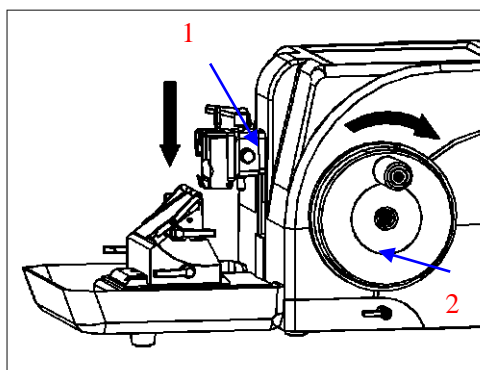

As the drawing shows , turn the handwheel (2) to drive the specimen clamp(1) moving in the vertical direction.

● To clockwise turn the handwheel when sectioning to obtain a best section.

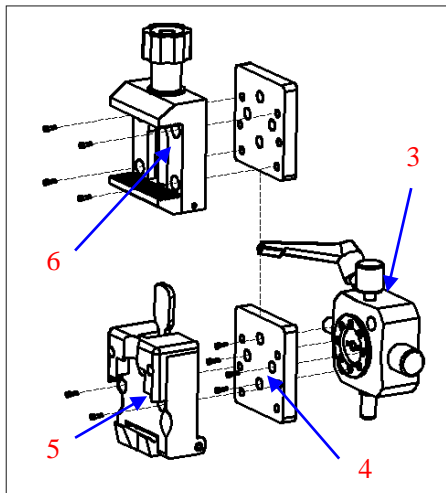

As drawing shows, the specimen clamping system is made up of adjustor(3)、connect board (4) and clamp(5、 6).

There are two kinds of clamp: specimen clamp (6) and Quick release cassette clamp (5).

Specimen clamp is fit for:

Dimension of specimen:40*50*30mm or the standard cassette.

Quick release cassette clamp is fit for:

Standard cassette.

Use the screws to fix each component as Fig shows. To change the specimen clamp, the user can loosen the screw connected the specimen and connector.

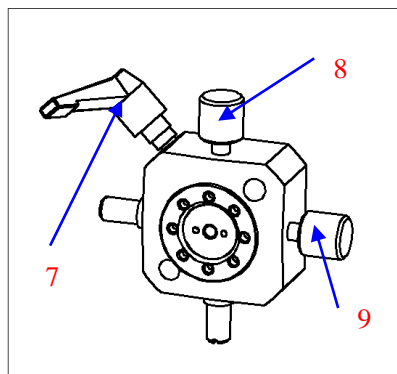

The specimen clamp adjustor

Loosen the lever 1 (7), and adjust the vertical knob (8) to calibration the vertical angle of the specimen; and the horizontal adjusting knob(9) can be used to adjust the horizontal angle of the specimen.

After the above, use the rotating lever 1 (7) to tighten it.

Specimen adjusting system:

horizontal orientation : $\pm 8^\circ$

vertical orientation: $\pm 8^\circ$

4.4 Specimen Clamps/Knife Inserting

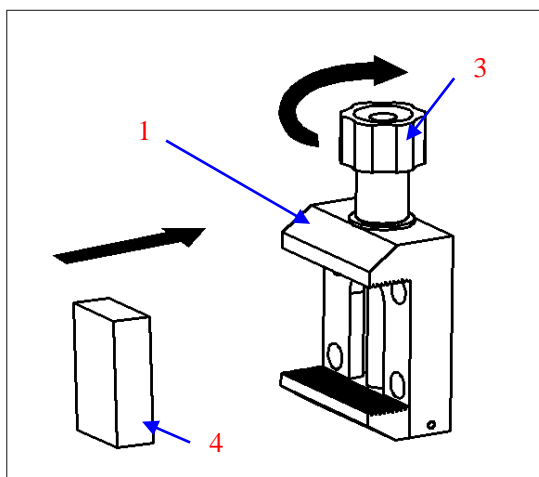

Specimen Clamp

The specimen Clamp is available two kinds: Specimen clamp (1) and Quick release cassette clamp (2) .

Specimen clamp:

Put the specimen (4) into the clamp (1) as it showed in the drawing. And then clockwise rotate the knurled screw (3) to tighten the clamp. And take down the specimen by rotating the knurled screw counterclockwise.

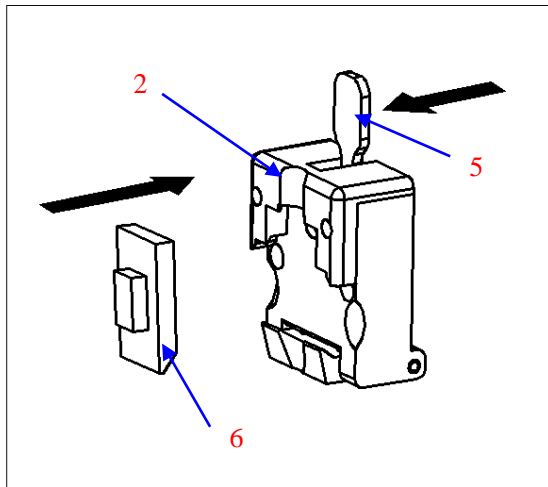

Quick release cassette clamp:

Push the lever (5) as the direction showed in the drawing to open the clamp(2), while put the specimen (6) into. and then free loosen lever (5), the specimen will be clamped automatically. To take down the specimen, just operate as above.

Easy to change the specimen by one hand operating the quick release cassette clamp.

- Always clamp the specimen before install the blade to avoid causing injury.

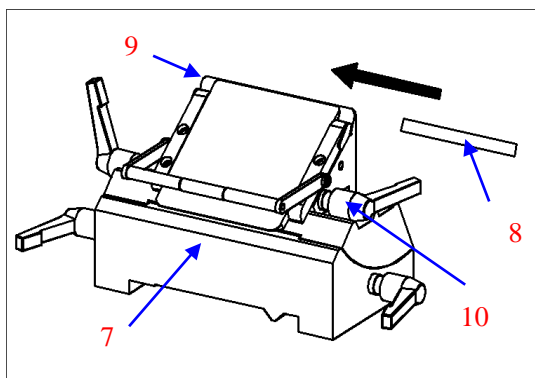

Blade Inserting

Loosen the lever 1(10), and then pull the blade (8) into the knife holder (7) as drawing shows direction, and then rotate the lever 1(10) to clamp the blade.

There are two kinds of blade can be used in the instrument: the Low disposable blade as it is showed in the picture and the High disposable blade.

If use HP blade, just loosen the two screws on the blade plate (9) to take out the base plate that is okay.

- Take care when operate the knife holder and the blade. The cutting edge is extremely sharp and can cause serious injury.

4.5 Trimming the specimen



- ⊙ Select the key, the screen will display the trimming setting.



- ⊙ Set the trimming thickness via this two keys.



- ⊙ Press these buttons to adjust the specimen back and forth to ensure the specimen is parallel with the cutting edge and wait trimming.

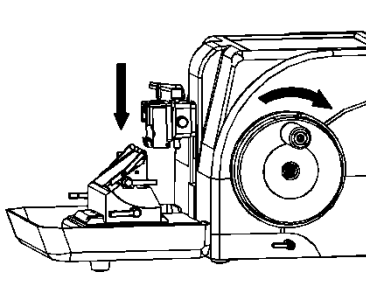

- ⊙ At last, check and ensure the three lever on the knife holder, lever on the base holder and the lever on the specimen clamping system all be locked. And then unlock the right handwheel to trim.

● Before change the specimen and the blade, the specimen clamping system must be centralized locked in upper.

4.6 Sectioning



- ⊙ Select the key, the screen will display the sectioning setting.



- ⊙ Set the sectioning thickness via this two keys.

- ⊙ After finish the above two steps and going to slicing .

To obtain a best section that need a high quality Microtome and a best blade, the following factors are also very important:

- The hardness of the specimen
- The angle of the cutting blade
- If the blade is clamped tightly
- If the specimen is clamped tightly.

To obtain a best section , first adjust a proper angle of the cutting blade and the specimen, the smaller the angle , the smaller the section compressed. And the harder the specimen the larger the angle. If the section is also not good, please try to increases the angle from zero.

● After sectioning, place the specimen clamping system on the upper position and lock it. Take out the blade and put it in the case box when it is not in use.

5、 Clearance & Maintenance

5.1 Cleaning the instrument

⊙ cleaning the appearance

Use the wet cloth to clean the areas always be touched when operate the instrument, for example the handle and the base holder locking lever and the storage area on the crust. Use the dry cloth to clean the other appearance.

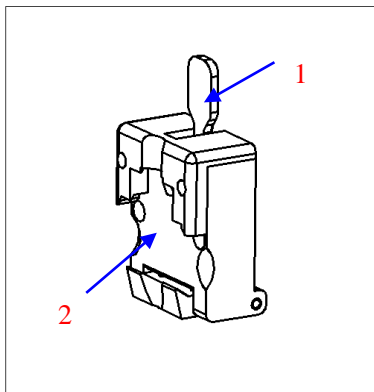

⊙ cleaning the clamp

Quick release cassette clamp

Position (1) which is often touched when operating, and position (2) which is often contacted with the specimens, especially position (2) are very easy to be polluted, so need to be cleaned frequently to ensure ordinary operation.

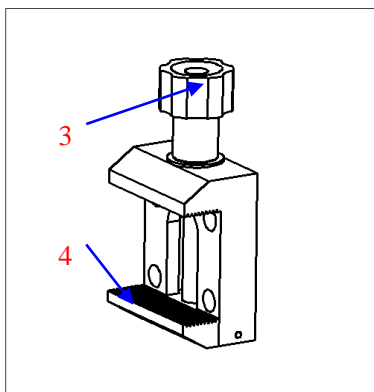

Specimen clamp

Position(3) which is often touched when operating and position (4) which is often contacted with the specimens, especially position (4) are very easy to be polluted, so need to be cleaned frequently to ensure ordinary operation.

⊙cleaning the knife holder

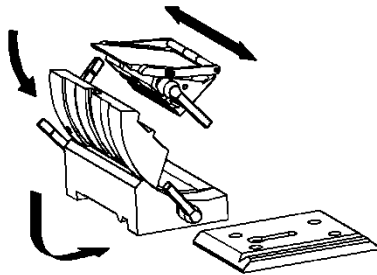

Take down all the parts of the knife holder as it is showed in the picture and then cleaning all the parts separately especially the following easily polluted parts: the slider, lever, blade clamp and the joint of the parts. And remember to clean the blade clamp every time before install the blade to ensure getting a good sectioning.

Rotate the corresponding Levers to split into : Clamp, X-axis slider, Y-axis slider and Z-axis slider

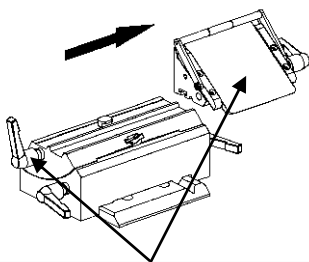

Clamp and its corresponding lever

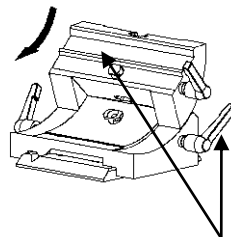

X-axis Slider and its corresponding lever

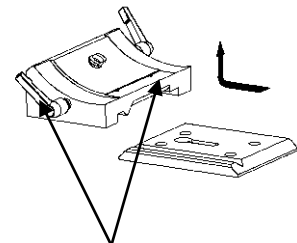

Y-axis Slider and its corresponding lever

To obtain a high quality section, it is important to keep cleaning the instrument. So the user must clean the instrument periodically or irregularly according to the total sectioning quantity to obtain the best section.

- only authorized and qualified service personnel may access the internal components of the instrument for clearance and maintenance!
- before clearance and maintenance turn the instrument off , pull out the plug and take down the knife holder and then clean all the parts of instrument separately. The blade must be taken down before cleaning the knife holder.
- lock the handwheel before each cleaning!
- do not use any solvents for cleaning!
- ensure that no liquids enter the interior of the instrument when cleaning!
- do not turn the instrument on before it is completely dry!

5.2 Maintenance

⊙ Replacing the Fuses

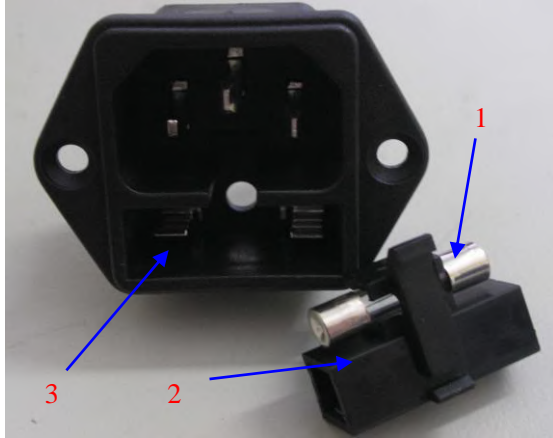

● put the fuse (1) in the installation part (2) and then insert the installation part into the socket(3).

● Cut off the power supply and pull out the plug before change the fuse.

Attention: before change the fuse, please read the operation manual carefully. And make sure to use the specified type fuse.

⊙ Maintenance for the knife holder

Lever, the fixed installations for the knife holder and other parts of the instrument which are frequently used and easily worn, need to be maintained regularly.

Take the lever down and oiled them to raise them service life.

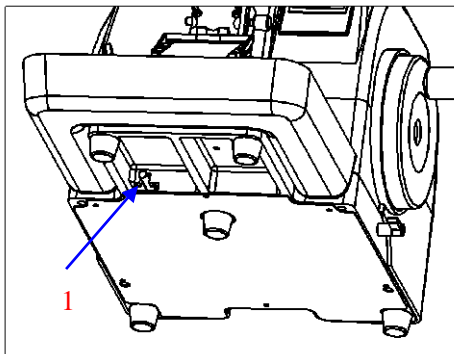

⊙ Balance

The balance of the handwheel is controlled by a spring in the instrument. And it will unbalance as the stress of spring changes along with the changing surrounding temperature and using period.

Raise the instrument from bottom and turn the nut (1) to make it balance.

6、 Trouble Shooting

Below you find a list of the problems that most frequently occur. And they are most caused by the operator, so please read the operation manual carefully before use it.

Problem	Possible causes	Corrective action
<ul style="list-style-type: none"> • No display, no reaction to buttons pressed after the instrument is switched on • Alarm is activated after switching the instrument on. • The section is uneven from the second section • The section is not continuous 	<ul style="list-style-type: none"> • Mains cable not properly connected or it is break in the circuit. 	<ul style="list-style-type: none"> • Check if mains cable is properly connected or replace the main cable
	<ul style="list-style-type: none"> • Mains fuses defective 	<ul style="list-style-type: none"> • Replace the fuses
	<ul style="list-style-type: none"> • The input voltage is not match with the voltage showed in the marks. 	<ul style="list-style-type: none"> • If it is not matched, call for the professional personnel.
	<ul style="list-style-type: none"> • The rapid-stopped switch is pressed 	<ul style="list-style-type: none"> • Check rapid-stopped switch and resume it
	<ul style="list-style-type: none"> • The cord connect control to the instrument is not or not well connected 	<ul style="list-style-type: none"> • Reconnect the control panel to the Instrument.
	<ul style="list-style-type: none"> • The sectioning angle of the knife is too small. 	<ul style="list-style-type: none"> • Alternately thick and thin sections are produced. In extreme case, every second section is skipped, being followed by a very thickness. Systematically try wider clearance angle setting until optimum angle width has been found.
	<ul style="list-style-type: none"> • The clamping setting is not steady 	<ul style="list-style-type: none"> • Check if all the screws are tightened.
	<ul style="list-style-type: none"> • The paraffin is too hard. 	<ul style="list-style-type: none"> • Embed the specimen again in the low-fusing paraffin or drop the embedded specimen into the low-fusing paraffin, and then trim the embedded specimen to make the thin
	<ul style="list-style-type: none"> • The angle between knife and the embedded cassette is too large. 	<ul style="list-style-type: none"> • Decrease the angle between knife and the embedded specimen.
	<ul style="list-style-type: none"> • The set sectioning thickness is too thick. 	<ul style="list-style-type: none"> • Adjust the setting thickness
<ul style="list-style-type: none"> • Blunt cutting edge 	<ul style="list-style-type: none"> • Replace the blade or adjust the position of the blade. 	

Problem	Possible causes	Corrective action
<ul style="list-style-type: none"> • The section is not continuous 	<ul style="list-style-type: none"> • Other reasons 	<ul style="list-style-type: none"> • Use an ink brush to smooth the section, and make the embedded cassette cling with one side of the blade edge, and if this method is effective, it can be applied afterwards and the section connection can be got in most situations.
<ul style="list-style-type: none"> • The section is curved or damaged 	<ul style="list-style-type: none"> • The wax appears wedge. • The embedded specimen is not parallel with the cutting edge • The cutting edge is irregular • The dense of paraffin is uneven • Other outside factors (light, heater or ventilation affect the temperature around the embedded specimen) 	<ul style="list-style-type: none"> • Trim the embedded specimen to make the top line parallel with the bottom line, and the width of the embedded specimen must be even. • Adjust the specimen clamping to ensure the top line and the bottom line of the embedded specimen parallel with the cutting edge. • Move the blade in horizon until there is no uneven edge. • Remove the uneven paraffin and embedded the specimen again. • Put the microtome in the room with constant temperature till the embedded specimen and the microtome to the required temperature to avoid these disadvantages.
<ul style="list-style-type: none"> • The section is extremely compressed, wrinkled or jammed together. 	<ul style="list-style-type: none"> • Blunt cutting edge • Ambient temperature is too high • The inclined angle of the knife is too small. • The blade edge is polluted by the remaining paraffin 	<ul style="list-style-type: none"> • Sharpen the knife or change the blade, or adjust the blade position in horizontal orientation. • Cool down the embedded specimen and blade with cold water or embed the specimen with the paraffin which is not too soft and not too hard. • Increase the angle to avoid the incline plane rubbing the embedded specimen. • Use the wet-cotton and the cleansing liquid to clean two sides of the blade from the bottom. Never clean the blade from the blade edge because it may damage the blade and result in personal injury.

Problem	Possible causes	Corrective action
<ul style="list-style-type: none"> The section is extremely compressed, wrinkled or jammed together. 	<ul style="list-style-type: none"> The wax has been used several times which cause the section damaged. 	<ul style="list-style-type: none"> Change the paraffin, and embedded the specimen again
<ul style="list-style-type: none"> The section is broken or the specimen is tore to pieces. 	<ul style="list-style-type: none"> The tissue is not completely dehydrated, or it is not cleaned correctly 	<ul style="list-style-type: none"> Dehydrate or clean the tissue again.
	<ul style="list-style-type: none"> If the specimen is soft or being paste, it means the specimen is not completely penetrated with paraffin. 	<ul style="list-style-type: none"> Penetrate the specimen with paraffin and embed it again (but if it is not totally penetrated, few can be penetrated and embedded again)
	<ul style="list-style-type: none"> The alcohol is not totally cleaned by cleanser before the specimen is totally penetrated by paraffin. 	<ul style="list-style-type: none"> Clean the alcohol completely
	<ul style="list-style-type: none"> The specimen is immersed in the paraffin too long, or the paraffin is too hot. 	<ul style="list-style-type: none"> The saving is impossible because of several damages to the tissue that is impossible to retrieve
	<ul style="list-style-type: none"> The specimen is too hard to the paraffin. 	<ul style="list-style-type: none"> Embed the specimen (tissue) again in the plastic (histo resin) or paraffin not too hard and not too soft.
<ul style="list-style-type: none"> The section splits or there is scratch in length orientation. 	<ul style="list-style-type: none"> The blade is uneven. 	<ul style="list-style-type: none"> Sectioning in the even edge of the blade or change the blade
	<ul style="list-style-type: none"> The blade is polluted. 	<ul style="list-style-type: none"> Cleaning it
	<ul style="list-style-type: none"> The specimen is scratched by hard particles. 	<ul style="list-style-type: none"> Filtrate the paraffin and pump it slowly
	<ul style="list-style-type: none"> There are calcareous or siliceous particles in the embedded specimen. 	<ul style="list-style-type: none"> Keep out of the calcareous or siliceous particles
<ul style="list-style-type: none"> The section sticks to the blade 	<ul style="list-style-type: none"> The blade is polluted. 	<ul style="list-style-type: none"> Clean the blade
<ul style="list-style-type: none"> The blade produces sounds when sectioning, and the sections are scratched and show vibrated mark 	<ul style="list-style-type: none"> The gradient of blade is not proper 	<ul style="list-style-type: none"> Reinstall the blade and adjust the gradient of the blade.

Problem	Possible causes	Corrective action
<ul style="list-style-type: none"> • The surface of the section is in wave. 	<ul style="list-style-type: none"> • The gradient of blade is not proper. 	<ul style="list-style-type: none"> • Re-adjust the gradient of the blade
<ul style="list-style-type: none"> • The section flies away and sticks to the microtome or other objects near the microtome. 	<ul style="list-style-type: none"> • It is affected by static. 	<ul style="list-style-type: none"> • Increase the surrounding humidity to get rid of the static

If there are any other troubles can not be resolved, please contact with the manufacturer.

7、 Instrument Diagram

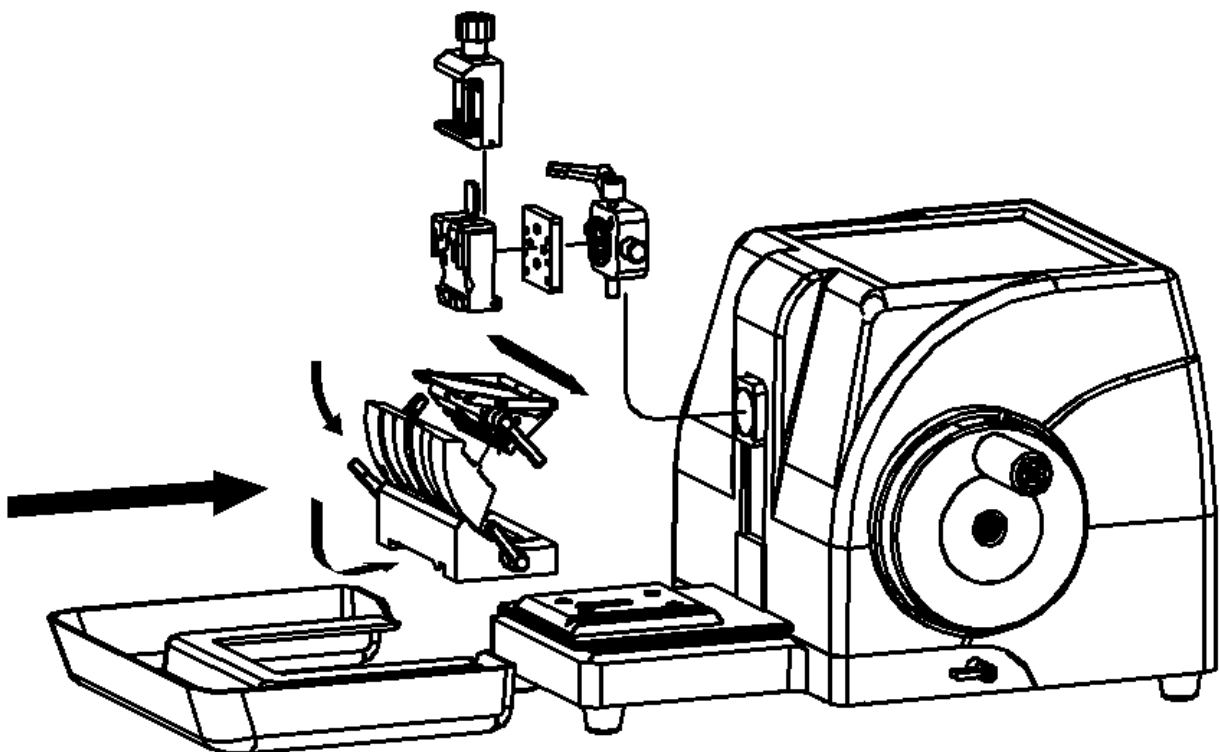

Standard accessories list

AEM450

No	Accessory Name	Qty	Notes
1	Microtome	1 unit	
2	Blade Holder	1 set	
3	Specimen Clamp	1 set	
4	Waste Tray	1 pc	
5	M3 Allen Wrench	1 pc	
6	M4 Allen Wrench	1 pc	
7	Dust Cover	1 pc	
8	Disposable blade	1 box	
9	Power cord	1 pc	
10	Fuse	2 pcs	2A
11	Operation Manual	1 pc	

Published by:



AMOS SCIENTIFIC PTY.LTD.

1 Prestige Dr Clayton South VIC 3169, Melbourne , AUSTRALIA

Tel: +61-4-10190188 Fax: +61-3-98081503

ABN 37 159 778 140

www.amos-scientific.com

Email: info@amos-scientific.com